

RD111

Toyota 8" IFS,53mm BRNG

PARTS LIST

ITEM #	QTY	DESCRIPTION	PART #	NOTES
01	1	BONDED SEAL	160702SP	
02	1	CLUTCH GEAR & WAVESPRING KIT	050906SP	
03	1	WAVESPRING	150706SP	
04	1	LONG CROSS SHAFT	060204SP	
05	1	SPIDER BLOCK	070201SP	
06	1	DIFFERENTIAL CASE	013007SP	
07	1	RETAINING PIN SET (PK OF 4)	120601SP	
08	---	TAPERED ROLLER BEARING	NOT SUPPLIED	
09	1	SHIM KIT	SHK009	
10	1	SEAL HOUSING KIT	081805SP	
11	1	SEAL HOUSING O-RINGS (PK OF 2)	160207SP	1
12	1	FLANGE CAP KIT	027307SP	
13	1	LOCKING SIDE GEAR	SEE NOTE	2
14	4	PINION THRUST WASHER	SEE NOTE	3
15	4	PINION GEAR	SEE NOTE	2
16	2	SHORT CROSS SHAFT	060403SP	
17	1	SIDE GEAR	SEE NOTE	2
18	2	SIDE GEAR THRUST WASHER	SEE NOTE	3
19	1	COUNTERSUNK SCREW (PK OF 2)	200213SP	
20	2	ANTI-FRICTION BUSHING (PTFE)	160804SP	
*	1	BULKHEAD FITTING KIT (BANJO TYPE)	170114	4
*	1	NYLON AIR LINE (6mm DIA X 6m LONG)	170314	4
*	1	SOLENOID VALVE (12V)	180103	
*	1	SWITCH	180209SP	
*	1	SWITCH COVER (FRONT)	180210SP	
*	1	CABLE TIE (PK OF 25)	180305	
*	1	OPERATING & SERVICE MANUAL	210200	
*	1	INSTALLATION GUIDE	2102111	

* *Not illustrated in exploded view*

NOTES

- 1 For replacement O-rings use only BS136 Viton 75.
- 2 Available only as complete 6 gear set # 728H111
- 3 Available only as complete thrust washer kit #730H01
- 4 All diffs produced before serial #17070001 came with 5mm air connection system. For information contact ARB.
- Spare axle retaining clips may be required (not supplied) to refit CV shafts.
- For 8" IFS with 50mm carrier bearings refer to RD131 ([Section 2.131](#)).
- For 8" IFS with 53mm carrier bearings refer to the numerically lower ring and pinion ratios (i.e., 3.73 & DN) refer to RD121 ([Section 2.121](#)).

RD111

Toyota 8" IFS, 53mm BRNG

EXPLODED DIAGRAM

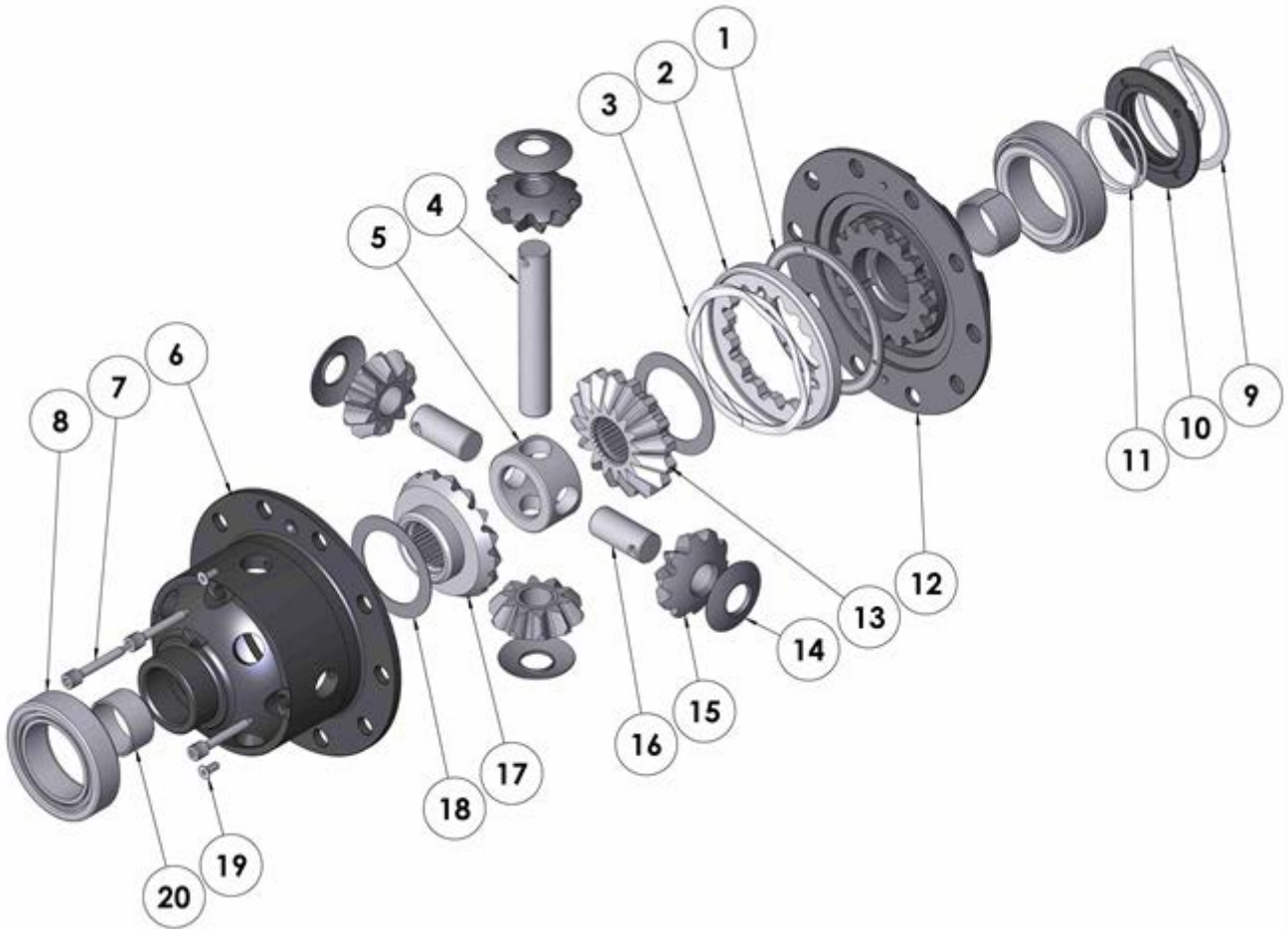

SPECIFICATIONS

Axle Spline	30 tooth, Ø33mm [1.31"]
Ratio Supported	3.91:1 & up
Ring Gear ID	126.0mm [4.96"]
Ring Gear OD	200mm [8"]
Ring Gear Bolts	10 bolts on Ø160mm [6.30"]
Ring Gear Torque	95Nm [70 ft-lb]
Backlash	0.15-0.25mm [0.006-0.010"]